



An introduction to Electric Vehicle Thermal Management System

Prof. Dr. Chen Jiangping

Director of SJTU Student Innovation Center

jpchen@sjtu.edu.cn

13661983031

Introduction to IMAC

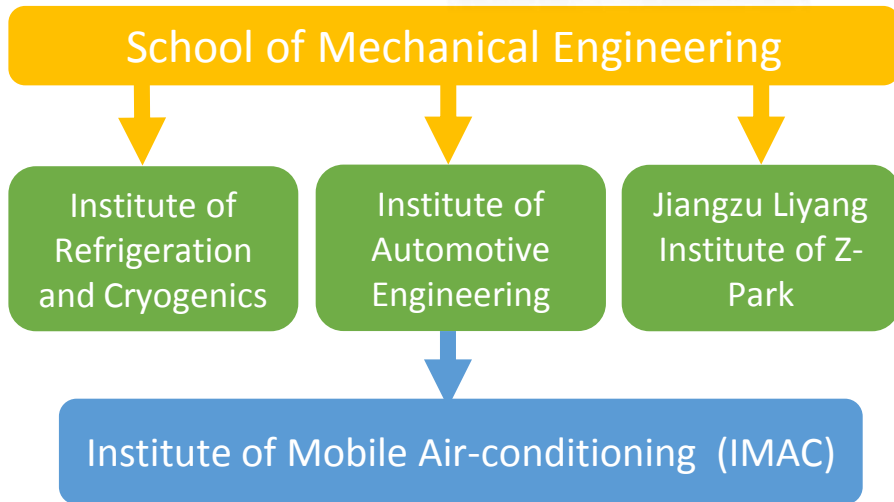

Team members: RA: Junye Shi ;
8 Phd candidates; 11 master candidates;
5 CFD engineers; 12 lab engineerings

■ Mobile Air Conditioning

- High-efficient MAC System
- Mobile **HP system** for EVs
- Natural Refrigerant (R290, CO2)
- Controller, Ejector, **Compressor**, etc.

■ Vehicle Thermal Management

- Thermal Comfort & Cabin Load
- **Battery Cooling** & Chiller
- Frontal module & Radiator, Oil Cooler

Mobile electrical compressor

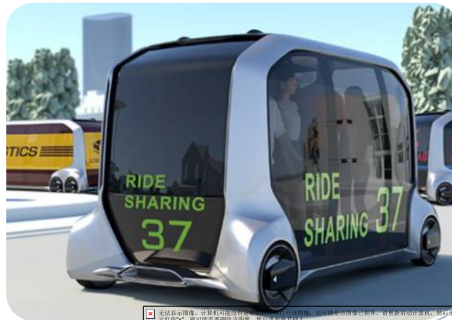

Scroll Movement



Orbiting Scroll

- 24V--800V DC
- Scroll type
- AC & HP mode
- Integrated inverter
- Less noise, weight



Mechanical Compressor

- Driven by engine belt
- Swash plate, wobble plate
- Only for AC mode

Electrical Compressor

Low AT
Operation

Natural
Refrigerant

Electrical
Compressor

- Scroll manufacture
- Inverter integration
- Motor control

- 20°C cold climate
- Back pressure
- Oil Circulation
- 120°C Discharge T

- CO₂ Refrigerant
- 12.5MPa Discharge P
- 150°C Discharge T
- POE Oil Properties
- Scroll material

Mobile electrical compressor



Back pressure match the condition variation
Positive valve & Passive Two Balancing Hole

High efficient cyclone oil separator
Oil & Gas ref & Liquid ref flow analysis

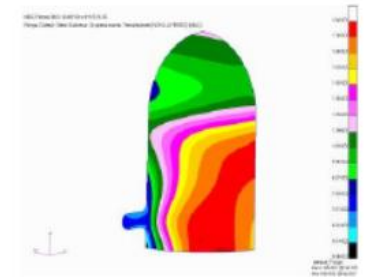
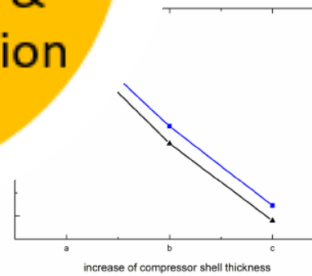
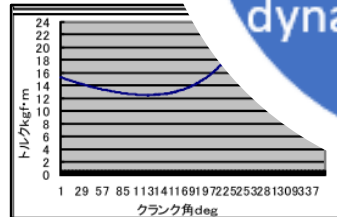
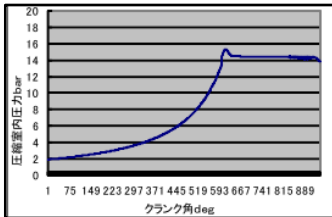
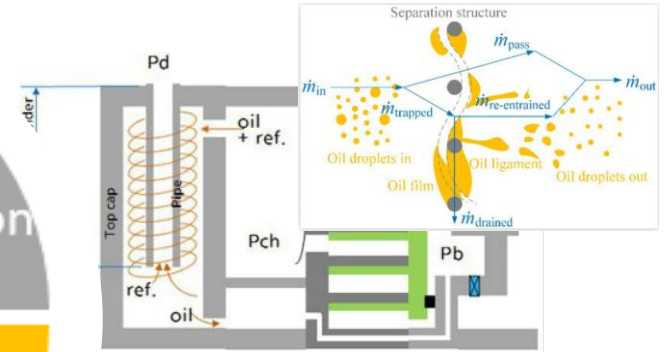
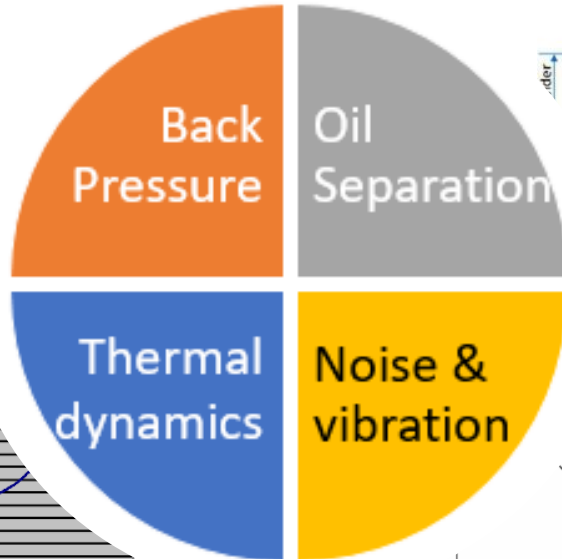
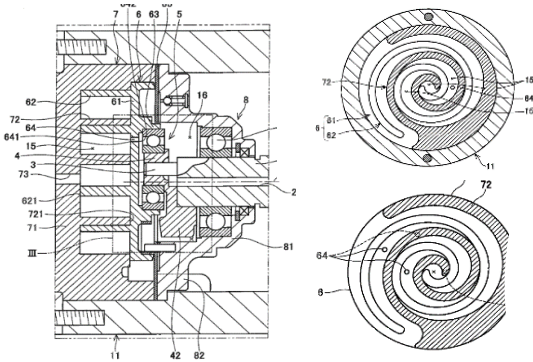

Scroll compression process thermal dynamic
Accurate prediction of T, P and Force
Novel application: EVI; CO2; R290

Analyzing the source of the noise
Dynamic balancing design
Scroll manufacture and measurement

Mobile electrical compressor



Compressor test facility

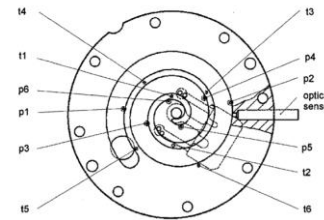
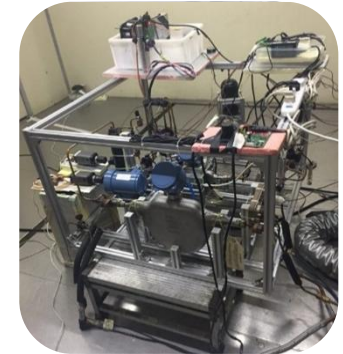

Collaboration Partners

GMCC 美芝

HIGHLY 海立

OBRIST

SONGZ

DunAn



Thermal management for NEV



Cabin heating: Heat pump

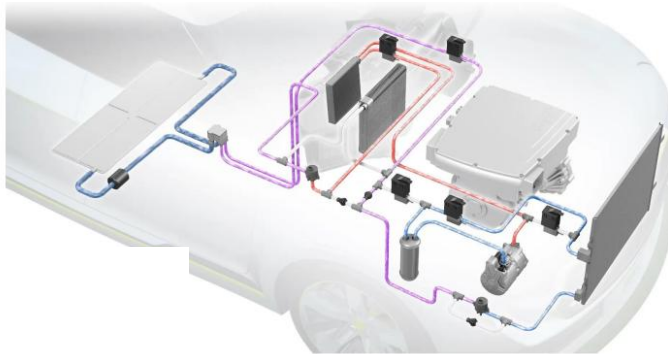

Smart controller

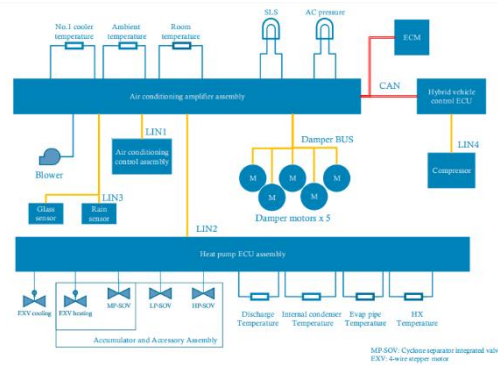

Battery Temperature control

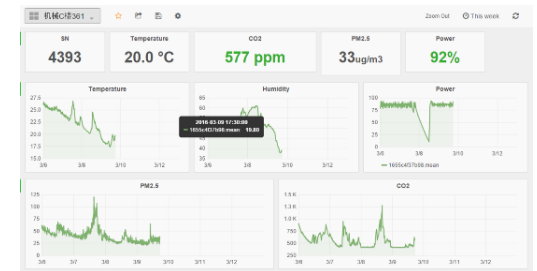
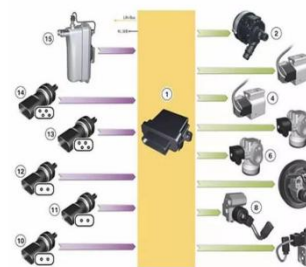
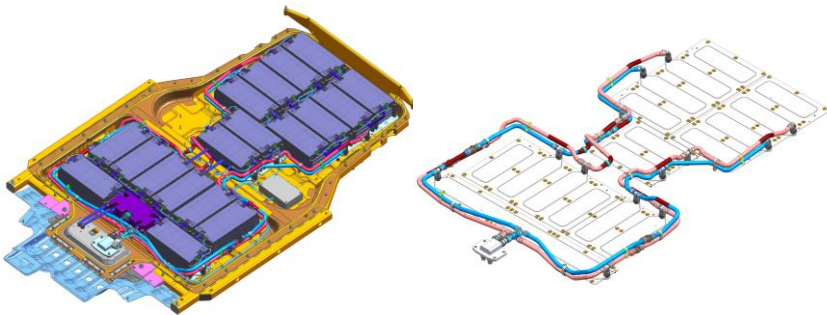

High efficient HP system

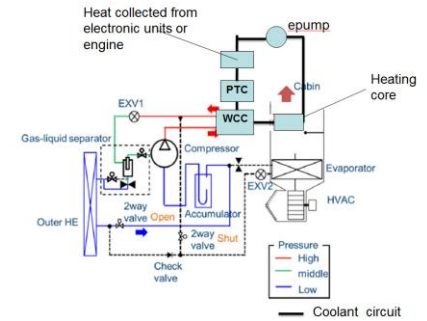
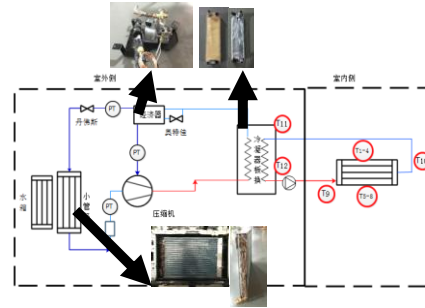

I-generation
Four-way valve

II-generation
Three HX

III generation
Vapor Injection System

IV generation
EVI + Battery

2003

2007

2010

2015

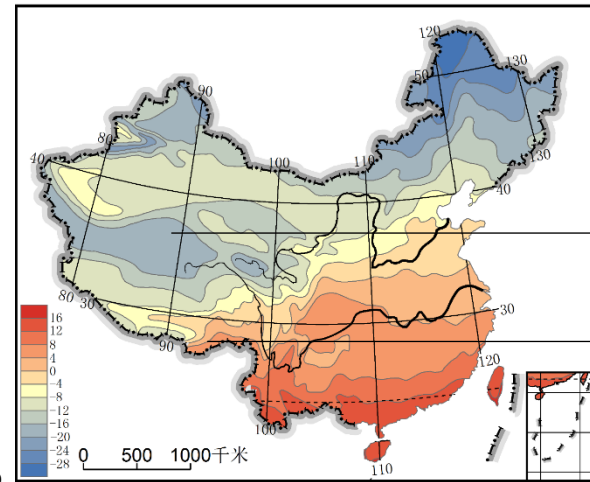
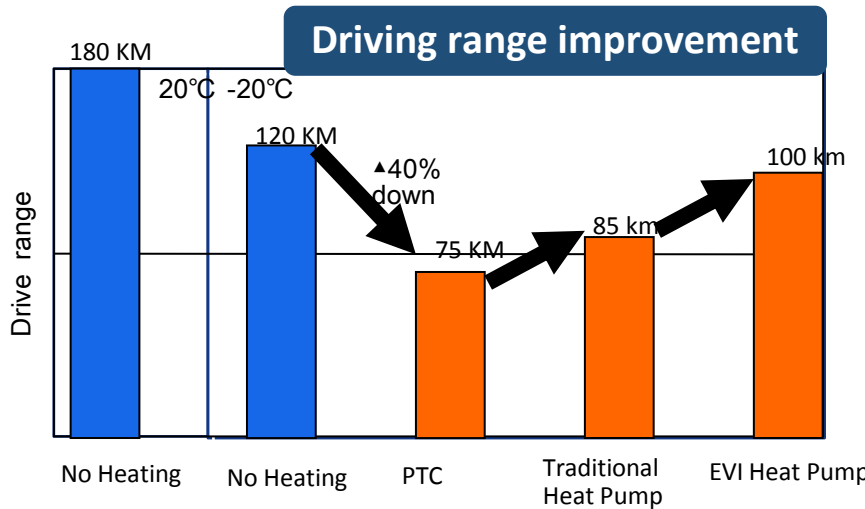

V Generation: CO2

- IV Generation
- III-generation
- II-generation
- I-generation

CO2 HP system

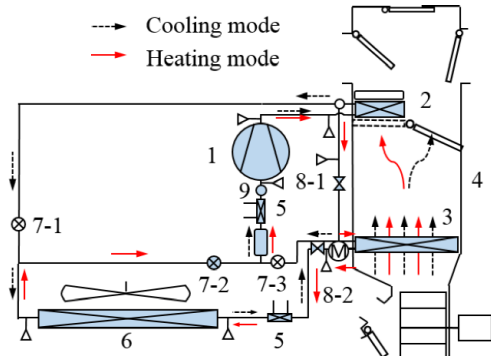

Novel SGC Design

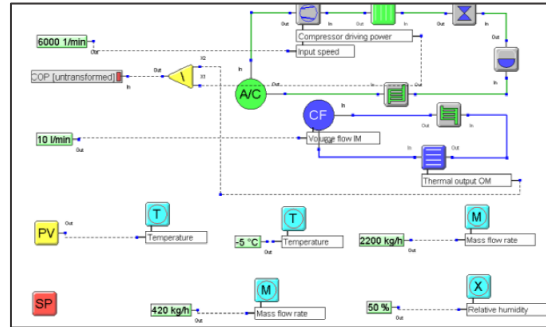

Prediction & Optimization

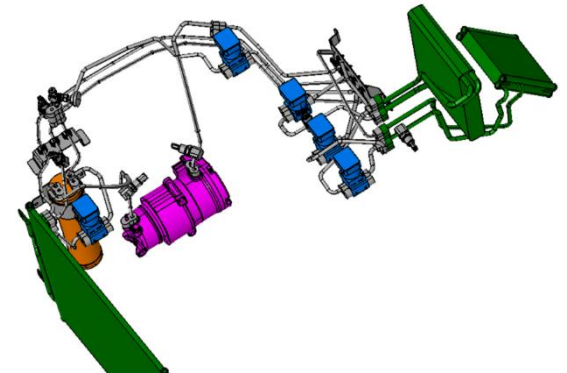

Prototype & Field Test

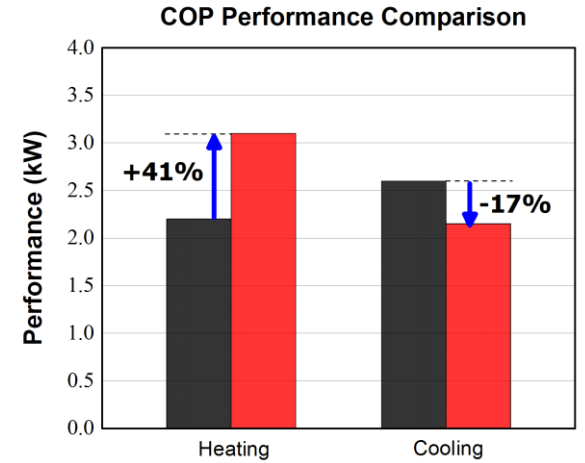
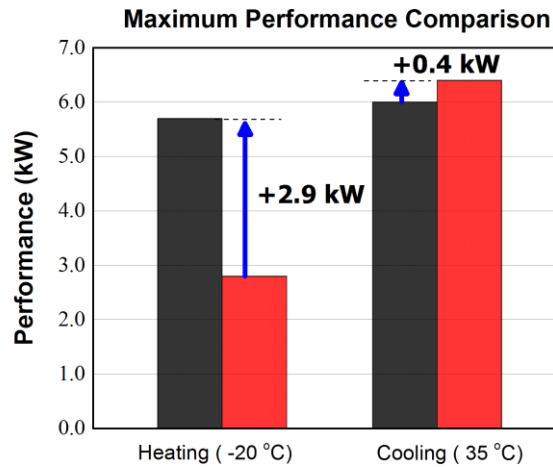
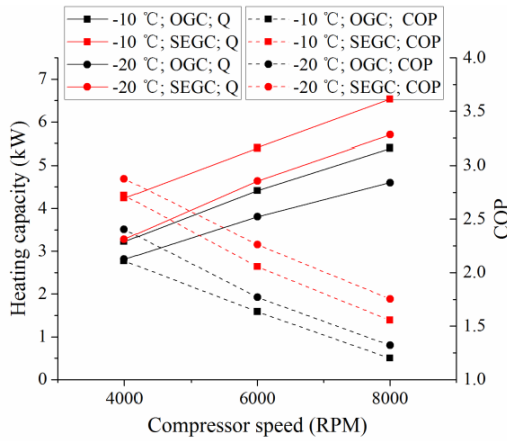

CO2 HP system & Ejector

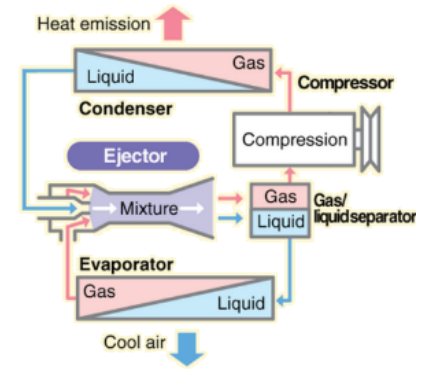
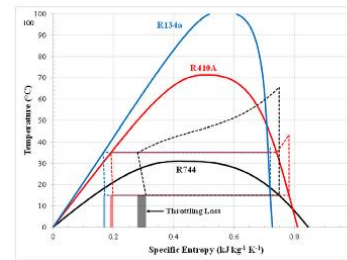
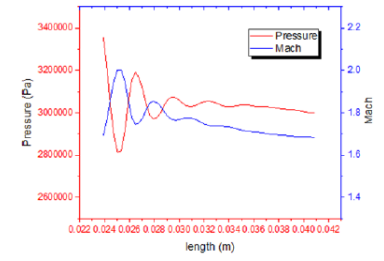
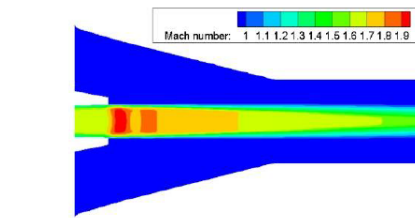
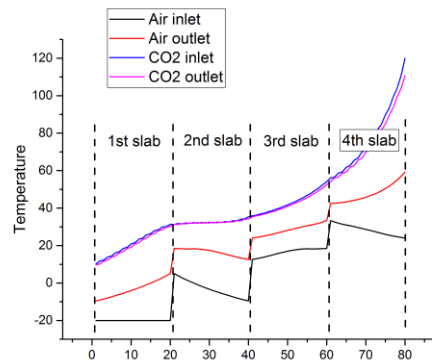
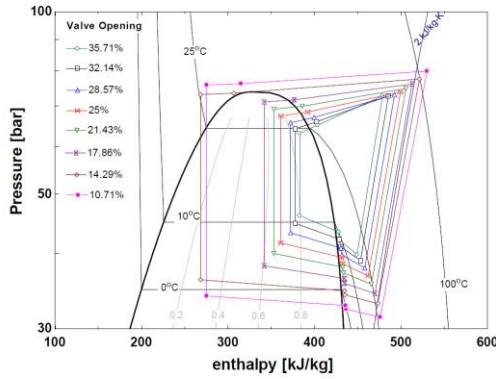

CO2 Microchannel HXs

R410A & CO2 Ejector

Battery cooling



Novel solution: Heat pipe technology

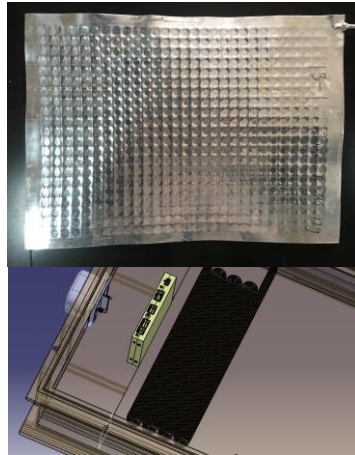
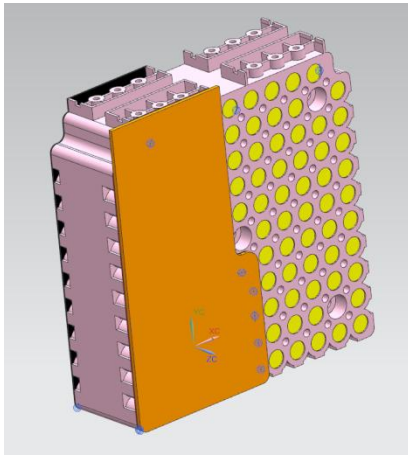

Cooling plate development

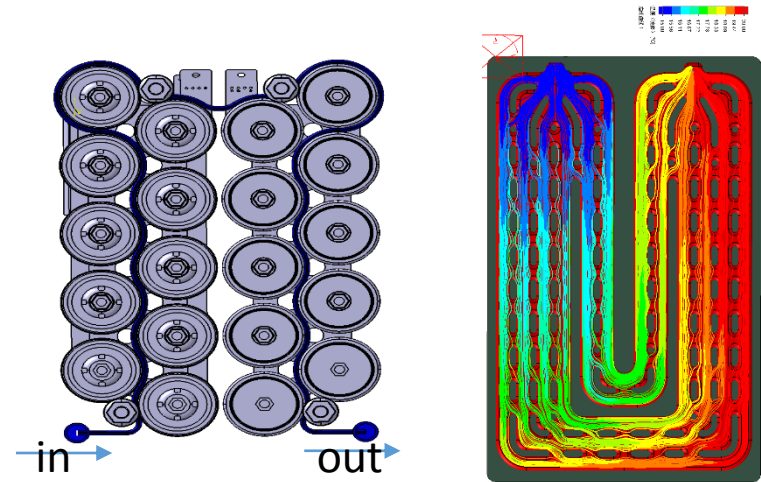

Battery package: Passenger vehicle

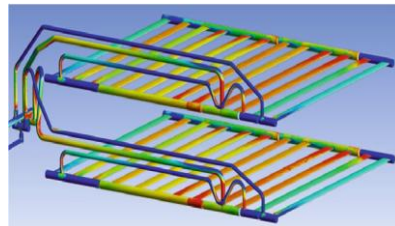
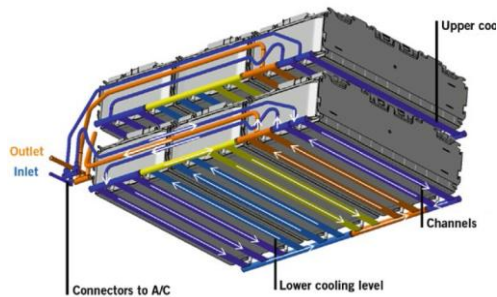

Battery package: Truck

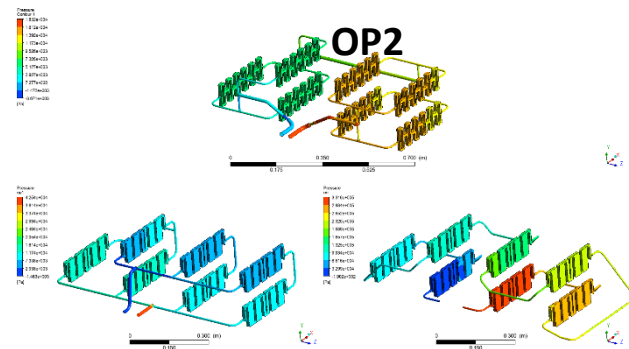

Thermal management for NEV



Liyang Research Center

- ✓ HP calorimeter facility
- ✓ Battery chiller test facility
- ✓ Environmental simulation lab
- ✓ Electrical compressor test facility
- ✓ Battery charging facility

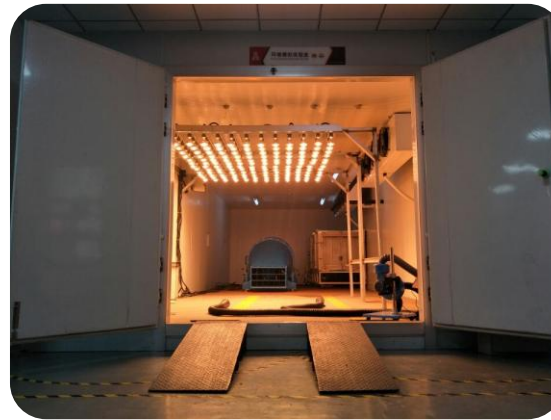

Thermal management for NEV

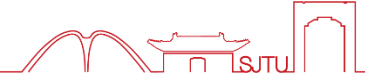

上汽集团
SAIC MOTOR



北汽集团
BAIC Group



长安汽车



上汽大众
SAIC VOLKSWAGEN



吉利汽车
GEELY AUTO



江淮汽车



Dun An



银轮股份
YINLUN CO.,LTD

